

TSUBAKI CHAIN COUPLINGS

FLEXIBLE COUPLINGS



FLEXIBLE COUPLINGS

Roller Chain Couplings

A flexible coupling manufactured with TSUBAKI's experience and technology to wind a sturdy two-strand roller chains around two sprockets.



Simple
Flexible
Durable
Wide Selection

Nylon Chain Couplings

The TSUBAKI Nylon Chain Coupling is a nonlubricated, clean flex coupling consisting of a nylon chain and a pair of coupling sprockets. A slip-fitted couple pin allows for easy assembly and disassembly. The Nylon Chain Coupling is ideal for application in the food and textile industries.

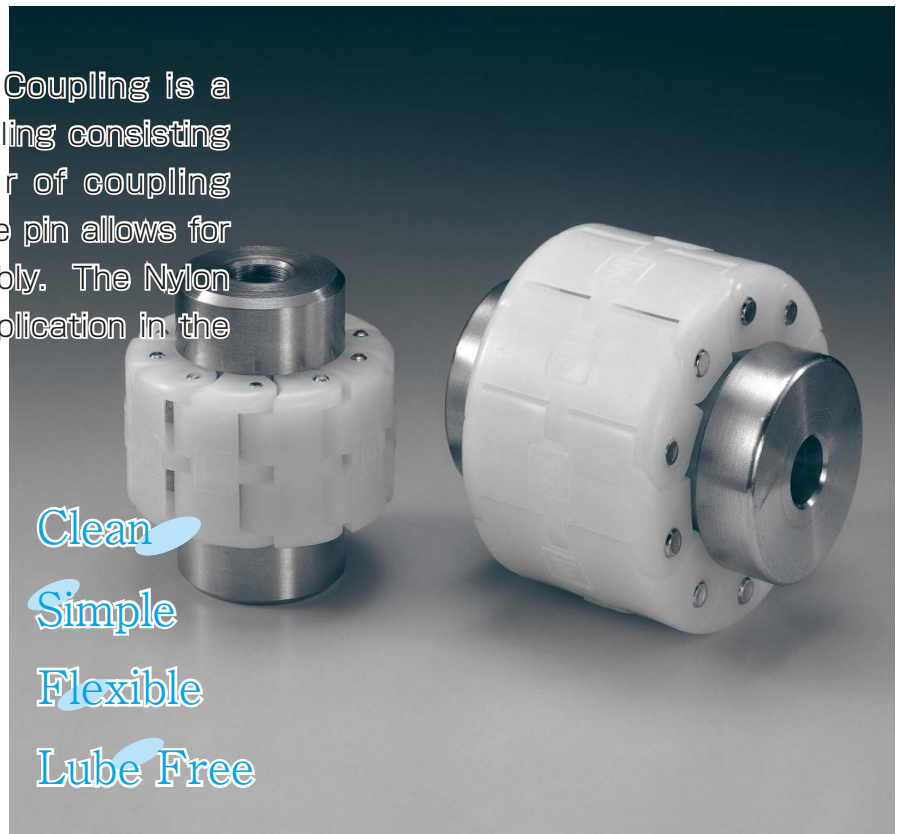

Clean
Simple
Flexible
Lube Free

Roller Chain Couplings

Features

Outstanding Durability

The coupling performs outstanding durability with the torque on the coupling shared with the surface-hardened teeth of the sprockets and the powerful roller chains that engage with the teeth.

Easy Coupling and Decoupling

Both shafts can be easily coupled or decoupled with a single joint pin inserted into or extracted from the roller chains.

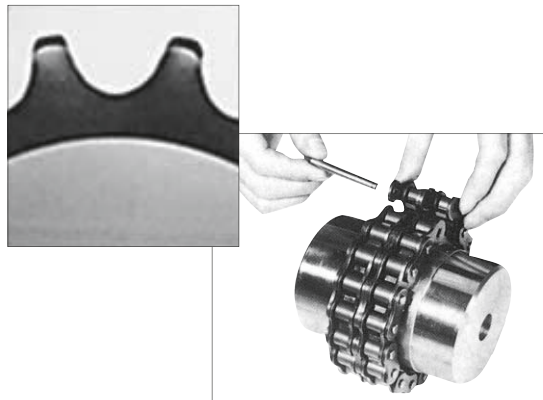

Absorption of Large Misalignment

The clearances between the chains and sprockets and between chain components absorb the great positional misalignment of both shafts.

Models in a Wide Variety

A total of 24 models including 15 models conforming to JIS and 9 other models are standardized.

(Roller chain shaft joint: Conforms to JIS B 1456-1989)

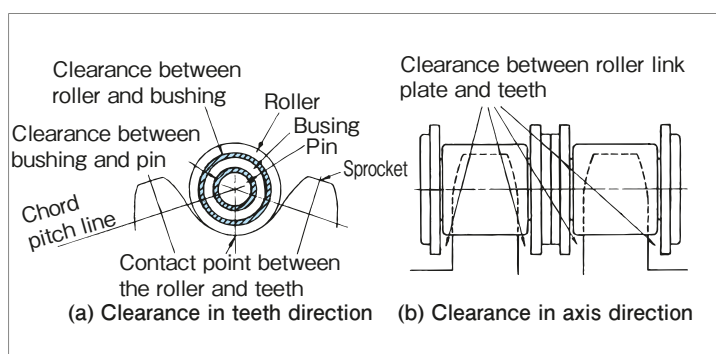

Eliminates time-consuming bore processing.

● Fit Bore Series —See page 7—

TSUBAKI offers 117 dimensions of standard bore processing and deliver them within a short time in response to orders.

The standard tolerance of bore processing is based on H7 and support to the tolerances of press fitting too.

Keyway tolerances are in conformity with new JIS Js9 and P9 and old JIS F7 and E9.

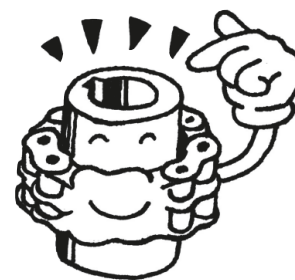

Ordering Information on Roller Chain Couplings

- Place each order with the product code and model number.

• Body with Pilot bore

Product code	Model no.	Quantity	Unit
P710001	CR3812H	10	K (units)

• Casing (Sold separately. Place orders if required.)

Product code	Model no.	Quantity	Unit
P710030	CR3812K	10	K (units)

- Model No.

Pilot Bore (Body)

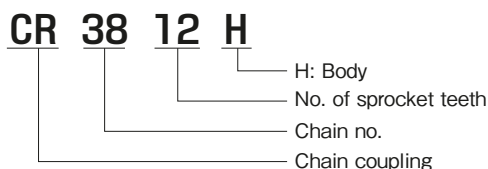

Casing

CR3812K

Dedicated casing: If required.

(Oil seal, packing, and mounting bolt included.)

Note: Place orders of body and casings separately.

Body Construction

Body

The body consists of two dedicated sprockets with hardened teeth and two-strand roller chains. The sprockets are coupled when the chains are wound around the sprockets, and decoupled with the chains removed. Therefore, transmission power can be coupled or separated without moving the transmission system.

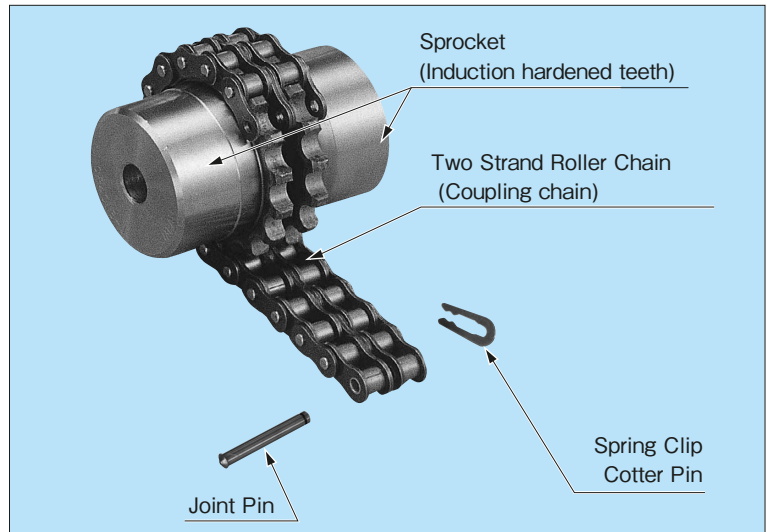

Dimensions (H)

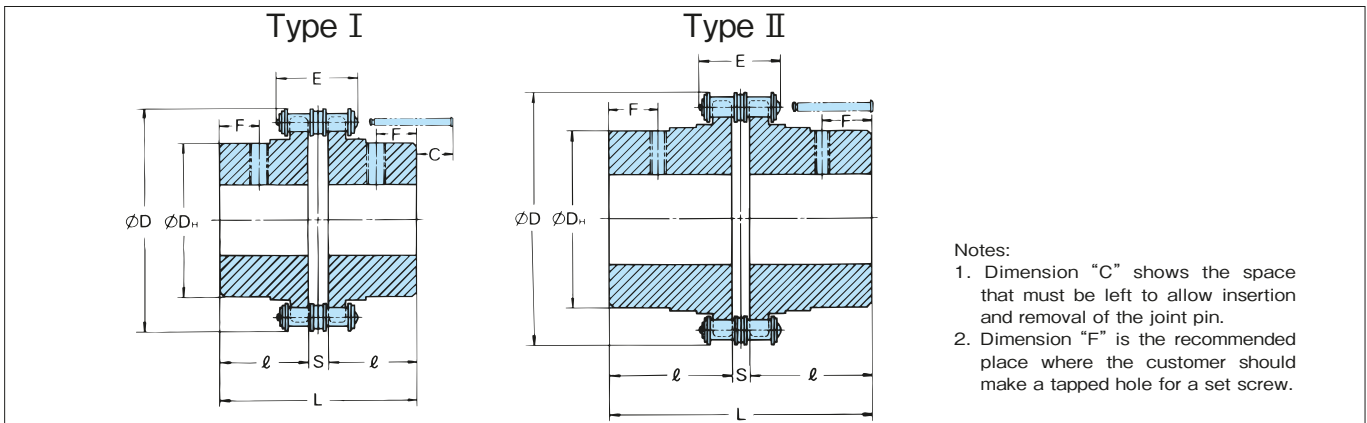

Unit: mm

Product code	Model no.	JIS code	Type	Pilot bore dia.	Bore dia.		Inertia kg·m ²	GD ² {kgf·m ² }	Chain		D	DH	L	R	S	C	F	Approx. Mass kg	
					Min.	Max.			Pitch	Max. Width									
P710001	CR 3812H	—	I	8	9.5	16	5.60×10 ⁻⁵	{2.24×10 ⁻⁴ }	9.525	24.0	45	25	64.9	30	4.9	4	14	0.3	
P710002	CR 4012H	4012		9	11	22	2.47×10 ⁻⁴	{9.89×10 ⁻⁴ }			61	35	79.4	36	7.4	10	16	0.8	
P710003	CR 4014H	4014		9	11	28	4.53×10 ⁻⁴	{1.81×10 ⁻³ }	12.70	33.1	69	43	79.4	36	7.4	10	16	1.1	
P710004	CR 4016H	4016		13	16	32	7.90×10 ⁻⁴	{3.16×10 ⁻³ }			77	50	87.4	40	6	20	1.6		
P710005	CR 5014H	5014		13	16	35	1.37×10 ⁻³	{5.49×10 ⁻³ }	15.875	41.0	86	53	99.7	45	9.7	12	21	3.6	
P710006	CR 5016H	5016			18	18	40	2.18×10 ⁻³			{8.72×10 ⁻³ }	96							60
P710007	CR 5018H	5018		18	18	45	3.53×10 ⁻³	{1.41×10 ⁻² }	19.05	51.1	128	85	123.5	56	11.5	15	26	6.5	
P710008	CR 6018H	6018		22	22	56	9.33×10 ⁻³	{3.73×10 ⁻² }			152	110							203
P710009	CR 6022H	6022		28	40	100	8.00×10 ⁻²	{3.20×10 ⁻¹ }	31.75	81.9	233	160	178.8	80	18.8	30	36	32.6	
P710010	CR 8018H	8018		23	32	80	3.63×10 ⁻²	{1.45×10 ⁻¹ }			25.40	65.3							170
P710011	CR 8022H	8022		28	40	100	8.00×10 ⁻²	{3.20×10 ⁻¹ }	38.10	102.7			203	140	222.7	100	22.7	40	46
P710012	CR10020H	10020		33	45	110	1.61×10 ⁻¹	{6.42×10 ⁻¹ }			50.80	131.7	233	160					
P710013	CR12018H	12018		43	50	125	2.68×10 ⁻¹	{1.07 }	63.50	160.6			256	170	202.7	90	22.7	50	36
P710014	CR12022H	12022		53	56	140	5.93×10 ⁻¹	{2.37 }			50.80	131.7	304	210					
P710015	CR16018H	16018		58	63	160	1.05	{4.19 }	63.50	160.6			405	224	254.1	112	30.1	68	42
P710016	CR16022H	16022		73	80	200	2.50	{9.99 }			63.50	160.6	405	280					
P710017	CR20018H	II	85	88	205	4.60	{1.84×10 }	63.50	160.6	426			294	519.5	241	37.5	—	100	294.4
P710018	CR20022H		95	98	260	1.07×10	{4.26×10 }			507	374	507	374						
P71	CR24022H		117	120	310	2.70×10	{1.08×10 ² }	76.20	197.3	608	420	751.1	353	45.1	—	150	871.4		
P71	CR24026H		147	150	380	5.70×10	{2.28×10 ² }			101.60	263.0							705	520
P71	CR32022H		197	200	430	1.08×10 ²	{4.32×10 ² }	127.0	332.3			806	570	1093	800	1099.6	512	75.6	—
P71	CR40020H		247	250	470	2.29×10 ²	{9.16×10 ² }			127.0	332.3	932	640						
P71	CR40024H		297	300	590	4.95×10 ²	{1.98×10 ³ }	127.0	332.3			1093	800	1255	960	1255	960	—	—
P71	CR40028H		347	350	700	9.48×10 ²	{3.79×10 ³ }			127.0	332.3	1255	960						

- Notes:
- The pilot bores of the items in bold are normally in stock, while those in regular typeface are made to order. If you require a size larger than those specified, please consult TSUBAKI.
 - The range of bore diameters for the CR4012-J to CR16022-J conforms to JIS standards. However, the minimum bore diameter can be of larger bore than the pilot bore. The maximum bore diameter shows the permissible bore diameter for standard smooth transmission with no impact or reverse rotation.
 - The items in regular typeface are made to order and the dimension "DH" is just for reference.
 - Inertia and GD² are based on pilot bore.

Kilowatt Ratings Table

Note: Be sure to follow the procedure on page 6 for the selection of couplings.

Unit: kW

Model no.	Max. bore dia. (mm)	Max. allowable transmission torque at below 50 r/min. (N·m)	Speed of rotation (r/min.)													
			1	5	10	25	50	100	200	300	400	500	600	800		
CR 3812	16	99.9	0.01	0.05	0.11	0.26	0.52	0.79	1.21	1.58	1.89	2.26	2.58	3.19		
CR 4012	22	217	0.02	0.11	0.22	0.58	1.15	1.73	2.63	3.46	4.15	4.96	5.67	7.01		
CR 4014	28	295	0.03	0.16	0.32	0.79	1.58	2.36	3.59	4.72	5.66	6.77	7.72	9.56		
CR 4016	32	386	0.04	0.21	0.41	1.03	2.06	3.09	4.69	6.17	7.41	8.85	10.1	12.5		
CR 5014	35	562	0.06	0.30	0.60	1.50	3.00	4.48	6.80	8.95	10.7	12.8	14.7	18.1		
CR 5016	40	735	0.08	0.39	0.78	1.95	3.91	5.86	8.92	11.7	14.1	16.8	19.2	23.8		
CR 5018	45	931	0.10	0.50	0.99	2.48	4.95	7.43	11.3	14.9	17.8	21.3	24.4	30.1		
CR 6018	56	1750	0.18	0.93	1.87	4.67	9.33	14.0	21.3	28.0	33.6	40.1	45.9	56.8		
CR 6022	71	2370	0.25	1.25	2.51	6.31	12.5	18.8	28.6	37.7	45.3	54.1	61.9	76.5		
CR 8018	80	3880	0.41	2.07	4.14	10.3	20.7	31.0	47.2	62.1	74.5	89.0	101	126		
CR 8022	100	5580	0.59	2.96	5.93	14.8	29.6	44.5	67.2	89.0	106	127	146	180		
CR10020	110	8780	0.93	4.66	9.33	23.3	46.6	70.0	106	140	168	200	229	283		
CR12018	125	13200	1.40	7.02	14.0	35.1	70.2	105	160	210	252	302	345	426		
CR12022	140	17100	1.81	9.07	18.1	45.3	90.7	136	206	272	326	390	446	551		
CR16018	160	28600	3.03	15.1	30.3	75.8	151	227	345	455	546	652	746	922		
CR16022	200	41700	4.43	22.1	44.3	110	221	333	506	665	799	954	1090	1350		
CR20018	205	57000	6.06	30.3	60.6	151	303	454	691	909	1090	1300	1490	1840		
CR20022	260	71900	7.63	38.2	76.3	191	382	572	871	1140	1370	1640	1880			
CR24022	310	129000	13.7	68.8	137	344	688	1030	1570	2060	2470	2960	3380			
CR24026	380	157000	16.7	83.7	167	418	837	1250	1900	2510	3010	3600				
CR32022	430	255000	27.2	136	272	680	1360	2040	2850	4080	4900					
CR40020	470	494000	52.6	263	526	1310	2630	3940	5990	7890	9470					
CR40024	590	602000	64.0	320	640	1600	3200	4800	7300	9600						
CR40028	700	717000	76.2	380	762	1900	3800	5700	8690	11400						
Lubrication type			I	II		III										

Unit: kW

Model no.	Max. bore dia. (mm)	Max. allowable transmission torque at below 50 r/min. (N·m)	Speed of rotation (r/min.)											
			1000	1200	1500	1800	2000	2500	3000	3600	4000	4800	5200	6000
CR 3812	16	99.9	3.88	4.41	5.35	6.25	6.73	8.12	9.44	11.0	12.0	14.0	14.8	16.7
CR 4012	22	217	8.53	9.68	11.6	13.7	14.8	17.9	20.7	24.1	26.3	30.8		
CR 4014	28	295	11.64	13.21	15.8	18.7	20.2	24.4	28.3	32.9	35.9	42.1		
CR 4016	32	386	15.3	17.3	21.0	24.4	26.3	31.9	37.0	43.0	46.9	54.9		
CR 5014	35	562	22.1	25.1	30.0	35.4	38.3	46.2	53.6	62.4				
CR 5016	40	735	28.9	32.9	39.9	46.4	50.0	60.6	70.4	81.6				
CR 5018	45	931	36.6	41.6	50.5	58.8	63.4	76.8	89.2					
CR 6018	56	1750	69.1	78.4	95.2	111	120	145						
CR 6022	71	2370	93.1	105	128	149	161	195						
CR 8018	80	3880	153	174	211	246	265							
CR 8022	100	5580	219	249	302	352	379							
CR10020	110	8780	345	392	476	554								
CR12018	125	13200	519	590	716									
CR12022	140	17100	671	762										
CR16018	160	28600	1122											
CR16022	200	41700	1640											
CR20018	205	57000												
CR20022	260	71900												
CR24022	310	129000												
CR24026	380	157000												
CR32022	430	255000												
CR40020	470	494000												
CR40024	590	602000												
CR40028	700	717000												
Lubrication type														

Lubrication System I :
Apply grease regularly on a monthly basis.

Lubrication System II :
Apply grease regularly on a weekly basis, or mount the casing filled with grease.

Lubrication System III :
Mount the casing filled with grease.

Refer to page 8 for lubrication method.

Casing Construction

Casing

For ease of mounting and inspection, the casing can be separated at a right angle to the shaft. The mating part to the hub is finished precisely to hold the hub firmly with no eccentricity. Furthermore, the other hole has a trapezoidal groove into which an oil seal is inserted for the prevention of oil leakage while holding the sprocket boss flexibly so that the flexibility of the coupling will not be lost.

The coupling life is notably extended due to the prevention of both lubricant spatter and the infiltration of dust particles when installing the casing, which ensures effective lubrication. The casing protects the unit from corrosion and ensures safe operation.

If the coupling with casing is used under frequent start and stop operation or large vibration, please consult TSUBAKI.

Be sure to mount the casing in the following cases.

- (1) The coupling is rotated at high speed (see the notes in the Kilowatt Ratings Table).
- (2) The coupling is used in an abrasive atmosphere, such as a place with dust and dirt.
- (3) The coupling is used in a corrosive atmosphere, such as a humid place.

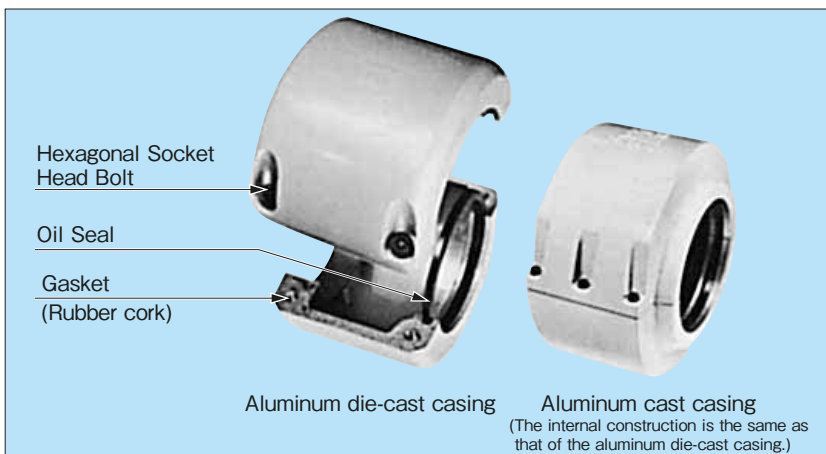

Casing (K)

Unit: mm

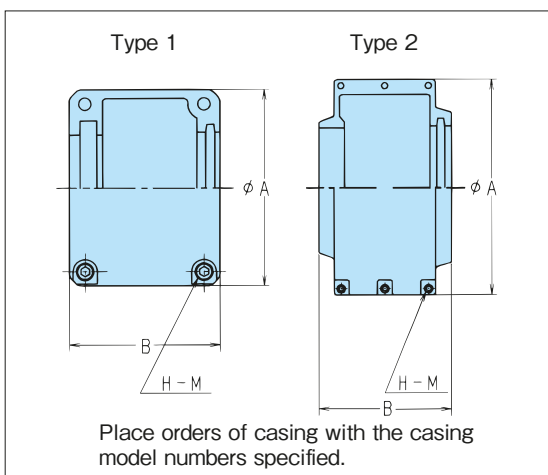

Coating specifications:

Aluminum die-cast casings are bake coated with melamin resin. Aluminum cast casings are bake coated with acrylic resin.

Coating color: Munsell 8.1YR7.6/15.2 orange yellow

Product code	Model no.	Type	Inertia (kg·m ²)	GD ² (kgf·m ²)	A	B	H-M	Oil seal	Casing material	Approx. mass (kg)
P710030	CR 3812K	1	1.55 × 10 ⁻⁴	{ 6.18 × 10 ⁻⁴ }	59	61	4-M5	Special type	Aluminum die-cast	0.19
P710031	CR 4012K		5.13 × 10 ⁻⁴	{ 2.05 × 10 ⁻³ }	75	75	4-M6			0.33
P710032	CR 4014K		6.53 × 10 ⁻⁴	{ 2.61 × 10 ⁻³ }	84					0.38
P710033	CR 4016K		8.58 × 10 ⁻⁴	{ 3.43 × 10 ⁻³ }	92	0.41				
P710034	CR 5014K		1.29 × 10 ⁻³	{ 5.16 × 10 ⁻³ }	101	85	4-M6			0.50
P710035	CR 5016K		1.81 × 10 ⁻³	{ 7.25 × 10 ⁻³ }	111					0.58
P710036	CR 5018K		2.35 × 10 ⁻³	{ 9.40 × 10 ⁻³ }	122	106	4-M8			0.66
P710037	CR 6018K		4.85 × 10 ⁻³	{ 1.94 × 10 ⁻² }	142					0.96
P710038	CR 6022K		9.35 × 10 ⁻³	{ 3.74 × 10 ⁻² }	167					1.3
P710039	CR 8018K		1.86 × 10 ⁻²	{ 7.43 × 10 ⁻² }	186	130	4-M8			2.0
P710040	CR 8022K	3.30 × 10 ⁻²	{ 1.32 × 10 ⁻¹ }	220	2.5					
P710041	CR10020K	6.60 × 10 ⁻²	{ 2.64 × 10 ⁻¹ }	250	148	4-M10	3.7			
P710042	CR12018K	7.63 × 10 ⁻²	{ 3.05 × 10 ⁻¹ }	307	181		※	3.3		
P710043	CR12022K	1.29 × 10 ⁻²	{ 5.15 × 10 ⁻¹ }	357	250	6-M10	3.9			
P710044	CR16018K	5.73 × 10 ⁻¹	{ 2.29 }	406			ZF48	14.7		
P710045	CR16022K	1.11	{ 4.45 }	472	ZF60	17.2				
P710046	CR20018K	1.42	{ 5.67 }	496	Special type	Aluminum alloy	22.2			
P710047	CR20022K	2.41	{ 9.66 }	578			26.6			

- Notes:
1. The casings of the items in regular typeface are made to order.
 2. The ZF type oil seal is made by NOK Co.
 3. The item marked ※ has 4 bolts and not 6, as indicated on the drawing.
 4. Refer to page 190 of service parts for the bolt length.

Selection

1. Operating Conditions Required for Selection

- (1) Daily operating hours
- (2) Load characteristics and type of motor
- (3) Transmission power (kW) and rotation speed (r/min) or torque (N·m)
- (4) Outer diameters of both shafts

2. Selection Method

- (1) Obtain the service factor from the table of service factors on the right-hand side according to the operating conditions.
- (2) Multiply the transmission power (or torque) by the service factor and obtain the correction transmission power (or correction transmission torque).
- (3) Select from the kilowatt ratings table a coupling that satisfy the corrected transmission power (or correction transmission torque) at the operating rotation speed.
- (4) If the required shaft diameter exceeds the maximum shaft diameter of the coupling selected, adopt a coupling a size larger.
- (5) The contact surface pressure may become excessive if a standard key is used. Calculate the contact surface pressure of the key and consider the necessity of using a special key or spline.
- (6) If the coupling is directly connected to the motor, select the coupling from the following table of recommended models for direct motor connection.

Table of Service Factors (SF)

Load Characteristics	Source of Power		
	Motor Turbine	Steam engine Gasoline engine (4 cylinders)	Diesel engine Gas engine
Low fluctuation, low impact, low starting torque, and no reverse rotation	1.0	1.5	2.0
Middle fluctuation, middle impact, and no reverse rotation (standard load)	1.5	2.0	2.5
High fluctuation, high impact, reverse rotation, and loaded starting	2.0	2.5	3.0

Note1. An increase according to the operating hour of the chain coupling (provided that the rotation speed is 50 r/min. or more).

8 to 16 hours/day: 0.5

16 hours or more/day: 1.0

2. The above table shows rough service factor standards. Decide on the service factor according to the operating conditions.

Reference: Relationship between torque, transmission, and rotation speed

$$T = \frac{60000 \times P}{2 \pi \times n} \quad \left\{ T = \frac{974 \times P}{n} \right\}$$

T : Torque N · m

P : Transmission power kW

n : Rotation speed r/min

3. Recommended Coupling Models for Direct Motor Connection

Motor Output kW	Motor shaft dia. mm	Model no.
0.1 0.2	11	CR3812
0.4	14	CR3812
0.75	19	CR4012
1.5	24	CR4014
2.2 3.7	28	CR4014

Note: The above motor is of 4-pole type with a totally enclosed external fan.

Motor capacity kW	Motor shaft dia. mm	Model no.
5.5 7.5	38	CR5016
11 15	42	CR5018
22	48	CR6018
30	55	CR6018
37 45	60	CR6022

4. Backlash

Model no.	CR3812	CR4012	CR4014	CR4016	CR5014	CR5016	CR5018	CR6018	CR6022
Backlash (Angle°)	±1.02	±1.06	±0.90	±0.79	±0.86	±0.75	±0.66	±0.62	±0.51

Model no.	CR8018	CR8022	CR10020	CR12018	CR12022	CR16018	CR16022	CR20018	CR20022
Backlash (Angle°)	±0.58	±0.47	±0.50	±0.42	±0.34	±0.31	±0.26	±0.33	±0.27

Note: The above figures are calculated value and not guaranteed. Consult your TSUBAKI representative for the backlash angles of other models.

5. Operating Ambient Temperature

– 10°C ~ 60°C

If the operating ambient temperature range is other than the above, refer to page 190 for information on special applications.

Fit Bore Series (with Finished Bore)

Processing Details

※Different processing details can be set on both sides separately.

Finished bore	Select the desired dimension from table 1 and the tolerance from table 2.
Keyway	Select the desired dimension and the tolerance from table 2.
Tap hole	Check with table 3. (Two points on a single side of the hub with setscrews provided)

Time for Delivery

	Bore tolerance	Keyway tolerance
Standard specifications	H7	Js9
Semi-standard specifications	R7, P7, N7, M7, Js7, G7	P9, F7, E9

Ordering Information on Fit Bore Series

■ Place each order with the product code and model number specified.

Product code	Model no.	Quantity	Unit
P710019	CR3812FB-H14J×H16J	10	K (units)

● Model No.

Fit Bore Series (Body)

CR6022FB-H35J × G40F

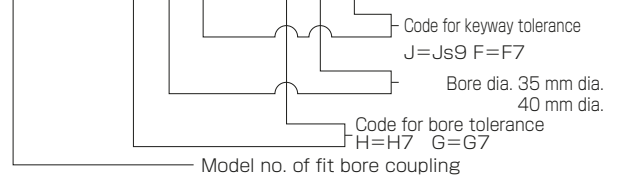

※The casing is sold separately.

List of Applicable bore (Table 1)

Product code	Model no.	Bore dia. mm																						
		14	15	16	17	18	19	20	22	24	25	28	30	32	35	38	40	42	45	48	50	55	60	65
P710019	CR3812FB-□□□□×□□□□	●	●	●																				
P710020	CR4012FB-□□□□×□□□□	●	●	●	●	●	●	●																
P710021	CR4014FB-□□□□×□□□□	●	●	●	●	●	●	●	●	●														
P710022	CR4016FB-□□□□×□□□□			●	●	●	●	●	●	●	●	●	●											
P710023	CR5014FB-□□□□×□□□□			●	●	●	●	●	●	●	●	●	●	●										
P710024	CR5016FB-□□□□×□□□□					●	●	●	●	●	●	●	●	●	●									
P710025	CR5018FB-□□□□×□□□□					●	●	●	●	●	●	●	●	●	●	●								
P710026	CR6018FB-□□□□×□□□□							●	●	●	●	●	●	●	●	●	●	●	●	●	●	●	●	●
P710027	CR6022FB-□□□□×□□□□									●	●	●	●	●	●	●	●	●	●	●	●	●	●	●
P710028	CR8018FB-□□□□×□□□□											●	●	●	●	●	●	●	●	●	●	●	●	●
P710029	CR8022FB-□□□□×□□□□															●	●	●	●	●	●	●	●	●
	New JIS key width mm	5	5	5	5	6	6	6	6	8	8	8	8	10	10	10	12	12	14	14	14	16	18	18
	Old JIS key width mm	5	5	5	5	5	5	5	7	7	7	7	7	10	10	10	10	12	12	12	12	15	15	18

※Fill out the boxes with the code for the bore tolerance, bore diameter, and code for the keyway tolerance in sequence (see the codes in table 2).

List of Bore and Keyway Tolerances (Table 2)

Tolerance symbol	Bore tolerance (Shaft tolerance : h6)							Bore dia. ϕd (mm)	New JIS parallel key JISB1301-1996					Old JIS parallel key					Bore dia. ϕd (mm)					
	Press fitting		Middle fitting			Loose fitting			Keyway width	Tolerance		Keyway depth	Setscrew	Keyway width	Tolerance		Keyway depth	Setscrew						
	R7	P7	N7	M7	Js7	G7	H7			Standard type	Press fit				Class 1	Class 2								
	R	P	N	M	J	G	H		Js9	P9	F7	E9												
Tolerance code	R	P	N	M	J	G	H	KW	J	P	KH		KW	F	E	KH								
Tolerance range mm	-0.016	-0.011	-0.005	0	± 0.009	+0.024	+0.018	14	5	± 0.0150	-0.012	2.3	M5	5	+0.022	+0.050	2	M5	14					
	-0.034	-0.029	-0.023	-0.018		15	16	17											18					
						19	20	22											24	25	28	30	32	35
					± 0.0105	+0.028	+0.021	19	6	± 0.0180	-0.015	2.8	M6	7	+0.028	+0.061	3	M6	22					
	-0.020	-0.014	-0.007	0		24	25	28											30					
	-0.041	-0.035	-0.028	-0.021		28	30	32											35	38	40	42	45	48
					± 0.0125	+0.034	+0.025	32	8	± 0.0215	-0.018	3.3	M8	10	+0.013	+0.025	3.5	M8	24					
	-0.025	-0.017	-0.008	0		38	40	42											45	48	50	55	60	65
	-0.050	-0.042	-0.033	-0.025		42	45	48											50	55	60	65		
					± 0.015	+0.040	+0.030	42	12	± 0.0215	-0.018	3.8	M8	12	+0.034	+0.075	5	M10	28					
	-0.030	-0.021	-0.009	0		48	50	55											60	65				
	-0.060	-0.051	-0.039	-0.030		50	55	60											65					
					± 0.015	+0.040	+0.030	55	14	± 0.0215	-0.061	4.3	M10	15	+0.016	+0.032	6	M10	32					
	-0.030	-0.021	-0.009	0		55	60	65																
	-0.060	-0.051	-0.039	-0.030		60	65																	

Note: Refer to the previous page for the dimensions of the body and casings. KW and KH dimensions are provided in the type information on the next page.

List of Set Screw Positional Relationships (Table 3)

Bore dia. d mm	14	15	16	17	18	19	20	22	24	25	28	30	32	35	38	40	42	45	48	50	55	60	65
Setscrew	M5	M5	M5	M5	M6	M6	M6	M6	M6	M6	M6	M6	M8	M8	M8	M8	M8	M8	M8	M8	M10	M10	M10
Old JIS key					M5	M5	M5																
CR3812FB																							
CR4012FB																							
CR4014FB																							
CR4016FB																							
CR5014FB																							
CR5016FB																							
CR5018FB																							
CR6018FB																							
CR6022FB																							
CR8018FB																							
CR8022FB																							

Type I

On keyway and 90° side

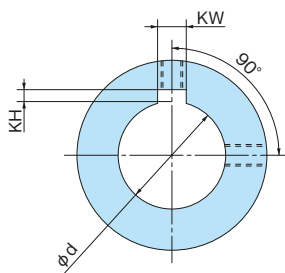

Type II

90° side and 180° side from keyway

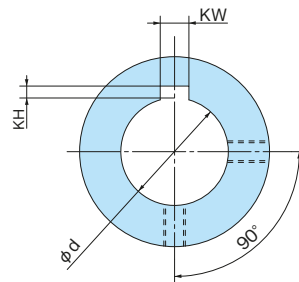

Type III

On keyway and 120° side

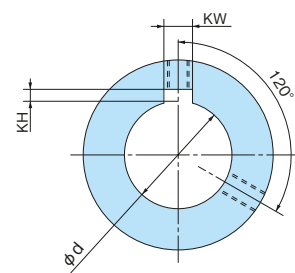

Lubrication

Lubrication

The following three lubrication systems are recommended when using Roller Chain Couplings. The choice depends on the operating speed. (Refer to the Kilowatt Ratings Table).

Lubrication System I

Apply grease regularly on a monthly basis.

Lubrication System II

Apply grease regularly on a weekly basis, or mount the casing filled with grease.

Lubrication System III

Mount the casing filled with grease. For System III, it is especially important to use high-grade grease because of grease stick to the inner surface of the case due to centrifugal force, resulting in poor lubrication. The following types of grease are recommended:

Manufacturer	Grease name
Exxon Mobil	Mobilux EP. 1 or 2
Shell	Alvania EP. 1 or 2

* Consistency: NLGI No. 1 or 2

Grease Change Interval for Lubrication System III

Operating conditions	Grease change interval	
	First change	Change interval after first change
Over ½ max. speed	1000hrs.	2000hrs.
Less than ½ max. speed	2000hrs.	4000hrs.

The amount of grease to apply is shown in the table below. If these amounts are adhered to, there will be slight leakage during initial operation, but this will soon stop.

Coupling no.	Amount of grease (kg)	Coupling no.	Amount of grease (kg)
CR 3812	0.04	CR 8018	0.6
CR 4012	0.07	CR 8022	0.8
CR 4014	0.08	CR10020	1.4
CR 4016	0.10	CR12018	2.6
CR 5014	0.12	CR12022	3.4
CR 5016	0.14	CR16018	6.6
CR 5018	0.20	CR16022	8.0
CR 6018	0.32	CR20018	10.1
CR 6022	0.40	CR20022	12.2

Special Use and Service Parts

Special Use

Floating Shaft Type

The standard product can be used as a floating shaft type as shown in the illustration below if there is a distance between applicable devices, provided that the shaft is in horizontal operation with minimal errors under the following limited operating conditions.

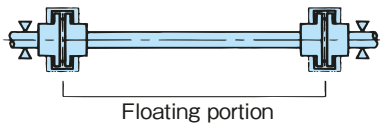

Operating conditions

1. The shaft is in horizontal operation.
2. The shaft in operation does not rotate in the reverse direction. The shaft may rotate in the reverse direction only after the shaft comes to a perfect stop.
3. The mounting errors are within the following ranges.

Angle error α : 0.5° max.

Parallel error ε : 1% max. of chain pitch

4. The maximum operating rotation speed and the permissible mass of the floating portion are within the ranges specified in the table.
5. Decide the length and diameter of the shaft in comparison with equivalent standard machinery parts.

Apply standard permissible transmission torque.

Model no.	Permissible mass of floating portion (kg)	Max. operating rotation speed (r/min)
CR 3812	19	250
CR 4012	36	250
CR 4014	35	200
CR 4016	35	200
CR 5014	62	150
CR 5016	62	150
CR 5018	61	150
CR 6018	83	100
CR 6022	79	100
CR 8011	136	50
CR 8022	128	50

Other Types for Special Use

Specifications	Applicable model	Content	Parts different from those of standard product
Heat resistant	CR4012~CR10020 (Consult your TSUBAKI representative for other types whenever required.)	Used if the operating ambient temperature is 60°C to 150°C.	E.g., oil seal, packing, body, and casing modification
Cold resistant		Used if the operating ambient temperature is -10°C to -40°C. Consult your TSUBAKI representative for the selection of models.	E.g., oil seal and main component (chain and sprocket)
Casing rotation stopper (with pin)		To prevent grease leakage with the casing rotation stopper because the operation of the chain coupling is start and stop frequently under horizontal use.	E.g., body and casing modification
Vertical use		Used to prevent grease leakage from the casing if the chain coupling is mounted vertically.	E.g., body and casing modification

Service Parts

Use the following dedicated parts at the time of servicing.

Service Parts for Roller Chain Coupling

Part name (Symbol)	Model legend	Content
Dedicated roller chain (C)	CR3812 <u>C</u>	Dedicated two strand roller chains and the joint pin specified in this table are provided.
Joint pin (JP)	CR3812 <u>JP</u>	A joint pin is provided along with a clip or cotter pin for retaining.
Oil seal (OR)	CR3812 <u>OR</u>	A dedicated rubber oil seal fit into the casing. The CR20018 or later ones are made of felt.
Gasket (OS)	CD3812 <u>OS</u>	A cork seat attached to the matching surface of the casing.

Sizes of Hexagonal Head Bolts for Casing

Model no.	Size	Model no.	Size
CR 3812	M 5×10	CR 8018	M 8×25
CR 4012	M 6×14	CR 8022	M 8×28
CR 4014	M 6×18	CR10020	M 8×28
CR 4016	M 6×18	CR12018	M10×35
CR 5014	M 6×18	CR12022	M10×35
CR 5016	M 6×18	CR16018	M10×45
CR 5018	M 6×18	CR16022	M10×45
CR 6018	M 8×25	CR20018	M10×45
CR 6022	M 8×25	CR20022	M10×45

- Note 1. Each size in the table indicate the nominal screw diameter and length of the corresponding bolt.
 2. The material is SCM435, strength grade of 12.9.

Installation

Installation

1. Place the oil seal on either the left or right sprocket. (Place the oil seal on upper side sprocket when vertical use.)

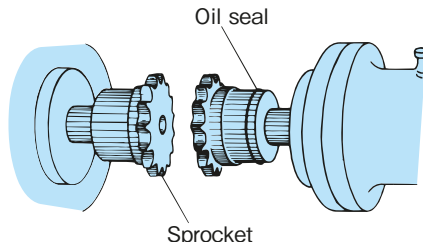

2. Bring the sprocket faces close together and correct the angular and offset misalignment.

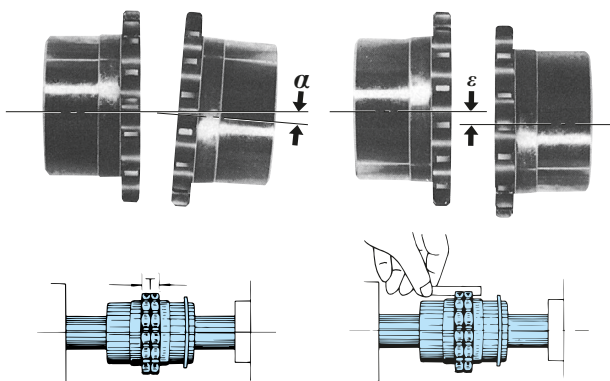

Adjust the angular misalignment (α) so that the dimension "T" is the same around the circumference of the sprockets. The allowable angular misalignment (α) is 1° .

Place a straight edge at the bottom of the corresponding teeth of the two sprockets and adjust in order to minimize the offset misalignment. The allowable offset misalignment (ϵ) is 2% of the chain pitch.

When the sprocket speed is 1/3 or more of the maximum speed, the allowable angular and offset misalignments are 0.5° and 1% of the chain pitch.

3. Measure the distance "S" between the sprocket faces and firmly fasten the set bolt (refer to the table of dimensions).

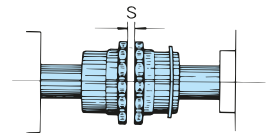

4. Fill the grease into the space "S" and lubricate the chain and teeth with grease, then wrap the chain around both sprockets and fix with the joint pin.

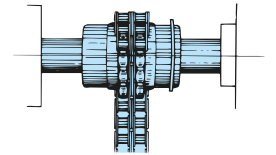

Insert the joint pin from oil seal side and confirm that the clip or cotter pin is securely fastened at counter oil seal side.

5. Fill the required quantity of grease into both sides of the casing and fasten them firmly. There will be slight leakage during initial operation, but this will soon stop. If the grease still leaks, check the conditions of installation.

Precautions for Additional Processing Work

Additional processing work on bore and keyway

In the case of processing and finishing the keyway and bore of a purchased product provided with a pilot bore (with no bore processed), perform the work based on the outer circumference of the hub. Be careful not to degrade tooth runout "a" or "b" in that case.

Do not perform additional processing work on the teeth and outer circumference of the hub.

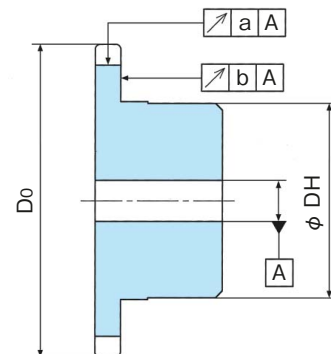

Permissible Misalignment

Model no.	CR3812	CR4012	CR4014	CR4016	CR5014	CR5016	CR5018	CR6018	CR6022
Permissible offset error (ϵ) mm	0.190	0.254	0.254	0.254	0.318	0.318	0.318	0.381	0.381
Permissible angular error (α)°	1	1	1	1	1	1	1	1	1
Permissible distance error (mm)	S±0.31	S±0.68	S±0.68	S±0.68	S±0.88	S±0.88	S±0.88	S±1.02	S±1.02

Model no.	CR8018	CR8022	CR10020	CR12018	CR12022	CR16018	CR16022	CR20018	CR20022
Permissible offset error (ϵ) mm	0.508	0.508	0.635	0.762	0.762	1.016	1.016	1.270	1.270
Permissible angular error (α)°	1	1	1	1	1	1	1	1	1
Permissible distance error (mm)	S±1.32	S±1.32	S±1.52	S±2.02	S±2.02	S±2.52	S±2.52	S $^{+1.0}_{-3.0}$	S $^{+1.0}_{-3.0}$

Note 1. Consult your TSUBAKI representative for the asterisk-marked values.

2. Each permissible error is acceptable on the condition that other errors are all zero.

Nylon Chain Couplings

■ Features

Corrosion Resistance

The TSUBAKI Nylon Chain Coupling is recommended where corrosion is a problem.

No Lubrication

Keeps your work environment clean without the dirt-catching problems caused by grease.

Quiet Operation

Contact between metal and nylon allows for quieter running than metal couplings.

Economical

Low installation and maintenance costs equal big savings.

Easy Assembly and Disassembly

■ Construction

The combination of chain and sprocket creates the absorption capacity for angular and offset misalignment..

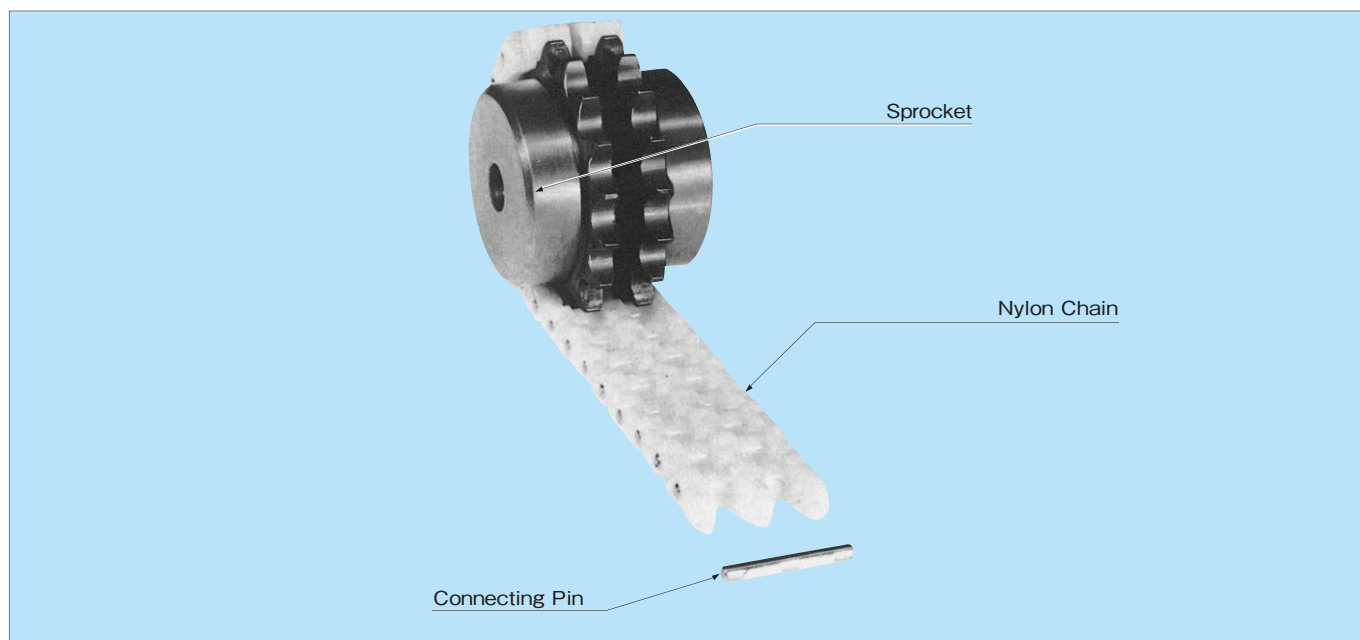

Ordering Information on Nylon Chain Couplings

- Place each order with the product code and model number.

Product code	Model no.	Quantity	Unit
P720010	CN310	10	K (units)

- Model No.

CN 3 10

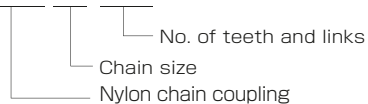

Dimensions

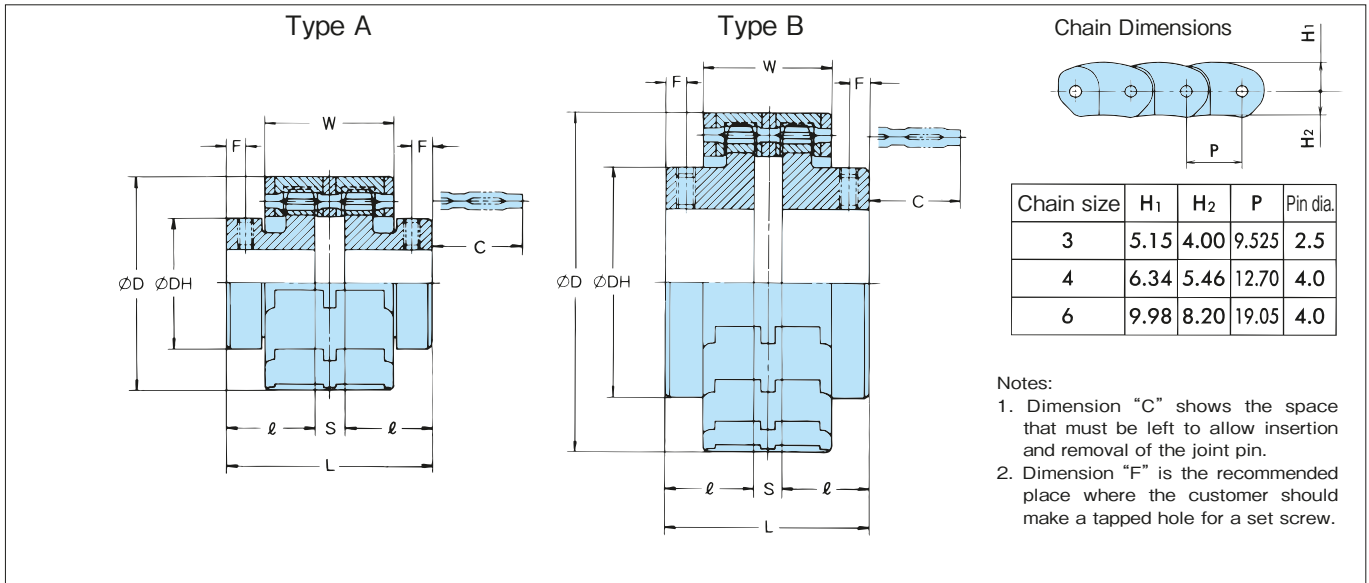

Unit: mm

Product code	Model no.	Type	Bore dia.		Inertia × 10 ⁻³ kg·m ²	GD ² × 10 ⁻³ (kgf·m ²)	D	DH	L	R	S	W	F	C	Approx. mass kg							
			Pilot bore	Max. bore																		
P720001	CN310	A	8.0	12.0	0.025	{ 0.10 }	39.6	25.0	46.0	20.0	6.0	23.2	6.0	12.3	0.2							
P720002	CN311			14.0	0.030	{ 0.12 }	42.7	27.0														
P720003	CN312			16.5	0.043	{ 0.17 }	45.8	31.0														
P720004	CN313			18.0	0.055	{ 0.22 }	48.9	32.0														
P720005	CN314	B	9.5	16.5	0.063	{ 0.25 }	52.0	30.0	46.0	20.0	6.0	23.2	6.0	12.3	0.3							
P720006	CN315			19.0	0.093	{ 0.37 }	55.1	35.0														
P720007	CN316			20.0	0.12	{ 0.46 }	58.2	37.0														
P720008	CN317			24.0	0.16	{ 0.62 }	61.3	41.0														
P720009	CN410	A	9.5	16.5	0.080	{ 0.32 }	51.8	32.0	51.2	22.0	7.2	32.0	5.0	22.8	0.3							
P720010	CN411			20.0	0.12	{ 0.47 }	55.9	37.0														
P720011	CN412			22.0	0.16	{ 0.64 }	60.1	40.0														
P720012	CN413			20.0	0.20	{ 0.78 }	64.2	37.0														
P720013	CN414	B	12.5	24.0	0.27	{ 1.07 }	68.3	42.0	51.2	22.0	7.2	32.0	6.0	22.8	0.6							
P720014	CN415			28.5	0.36	{ 1.42 }	72.4	46.0														
P720015	CN416			30.0	0.49	{ 1.84 }	76.5	50.0														
P720016	CN417			32.0	0.59	{ 2.35 }	80.6	54.0														
P720017	CN418			35.0	0.73	{ 2.90 }	84.7	57.0														
P720018	CN419			39.5	0.93	{ 3.71 }	88.8	62.0														
P720019	CN610			A	12.5	30.0	0.58	{ 2.33 }								78.6	49.0	73.5	32.0	9.5	47.5	8.0
P720020	CN611	32.0	0.81			{ 3.23 }	84.8	51.0														
P720021	CN612	32.0	1.07			{ 4.26 }	91.1	51.0														
P720022	CN613	35.0	1.46			{ 5.85 }	97.2	57.0														
P720023	CN614	B	16.0	39.5	1.94	{ 7.75 }	103.4	62.0	73.5	32.0	9.5	47.5	8.0	35.0	2.2							
P720024	CN615			45.5	2.55	{ 10.2 }	109.5	68.0														
P720025	CN616			47.5	3.28	{ 13.1 }	115.7	73.0														
P720026	CN617			47.5	3.88	{ 15.5 }	121.6	73.0														
P720027	CN618			55.0	5.75	{ 23.0 }	128.0	83.0								89.5	40.0	9.5	47.5	8.0	35.0	2.9
P720028	CN619			55.0	6.55	{ 26.2 }	134.1	83.0														
															4.6							

- Note 1. All products with pilot bore are in stock. Products other than the above are made to order.
 2. Finished holes, keyway, and setscrew holes can be processed by request, provided that the processing charges will be claimed separately. (Standard bore tolerance will be H8 unless otherwise specified.)
 3. Inertia, GD², and approximately mass are based on pilot bore.
 4. Orders of nylon chains for replacement are accepted.

Kilowatt Ratings Table

unit: kw

Model no.	Max. bore dia. (mm)	Allowable torque for below 100 r/min (N·m)	Speed of rotation (r/min)																	
			100	200	300	400	500	600	700	800	900	1200	1500	1800	2000	2500	3000	3600	4000	5000
CN310	12.0	6.86	0.07	0.14	0.22	0.29	0.36	0.40	0.44	0.48	0.51	0.61	0.70	0.79	0.85	0.98	1.1	1.2	1.3	1.8
CN311	14.0	8.82	0.09	0.18	0.28	0.37	0.46	0.51	0.56	0.61	0.65	0.79	0.90	1.0	1.1	1.3	1.4	1.6	1.7	2.0
CN312	16.5	10.8	0.11	0.23	0.34	0.45	0.56	0.63	0.69	0.75	0.80	0.96	1.1	1.2	1.3	1.5	1.7	2.0	2.1	2.5
CN313	18.0	12.7	0.13	0.27	0.40	0.53	0.67	0.74	0.81	0.88	0.95	1.1	1.3	1.5	1.6	1.8	2.0	2.32	2.5	2.9
CN314	16.5	14.7	0.15	0.31	0.46	0.62	0.77	0.86	0.94	1.0	1.1	1.3	1.5	1.7	1.8	2.1	2.4	2.7	2.9	3.4
CN315	19.0	16.7	0.17	0.35	0.52	0.70	0.87	0.97	1.1	1.15	1.23	1.5	1.7	1.9	2.1	2.4	2.7	3.0	3.2	3.8
CN316	20.0	18.6	0.20	0.39	0.59	0.78	0.98	1.1	1.2	1.3	1.4	1.7	1.9	2.1	2.3	2.7	3.0	3.4	3.6	4.3
CN317	24.0	21.6	0.23	0.45	0.68	0.90	1.1	1.3	1.4	1.5	1.6	1.9	2.3	2.5	2.7	3.1	3.5	3.9	4.2	4.9
CN410	16.5	25.5	0.27	0.53	0.80	1.1	1.3	1.5	1.6	1.8	1.9	2.3	2.6	2.9	3.1	3.6	4.1	4.6	4.9	5.8
CN411	20.0	30.4	0.32	0.64	0.96	1.3	1.6	1.8	2.0	2.1	2.3	2.7	3.1	3.5	3.8	4.4	4.9	5.6	6.0	7.0
CN412	22.0	36.3	0.38	0.76	1.1	1.5	1.9	2.1	2.3	2.5	2.7	3.2	3.7	4.2	4.5	5.2	5.9	6.6	7.1	8.4
CN413	20.0	42.1	0.45	0.89	1.3	1.8	2.2	2.5	2.7	3.0	3.2	3.8	4.4	4.9	5.3	6.1	6.9	7.8	8.4	9.8
CN414	24.0	49.0	0.51	1.0	1.6	2.1	2.6	2.9	3.2	3.4	3.7	4.4	5.1	5.7	6.1	7.0	7.9	9.1	9.6	11.2
CN415	28.5	56.8	0.59	1.2	1.8	2.4	3.0	3.3	3.6	3.9	4.2	5.0	5.8	6.5	7.0	8.1	9.2	10.4	11.1	13.1
CN416	30.0	63.7	0.67	1.3	2.0	2.7	3.4	3.8	4.1	4.5	4.8	5.7	6.6	7.4	7.9	9.2	10.4	11.7	12.6	
CN417	32.0	72.5	0.76	1.5	2.3	3.0	3.8	4.2	4.6	5.0	5.4	6.5	7.4	8.4	8.9	10.3	11.6	13.2	14.2	
CN418	35.0	81.3	0.85	1.7	2.6	3.4	4.3	4.7	5.2	5.6	6.1	7.2	8.4	9.3	10.0	11.6	13.0	14.8	15.9	
CN419	39.5	90.2	0.95	1.9	2.8	3.8	4.7	5.3	5.8	6.3	6.7	8.1	9.2	10.4	11.2	12.9	14.5	16.5		
CN610	30.0	102	1.1	2.1	3.1	4.1	5.1	6.1	7.0	7.9	8.8	11.3	13.6	15.6	16.9	19.6	21.7	23.4	24.1	
CN611	32.0	117	1.2	2.4	3.6	4.7	5.8	6.9	8.0	9.0	10.0	12.8	15.3	17.6	19.0	21.8	24.0	25.6		
CN612	32.0	132	1.4	2.7	4.1	5.3	6.6	7.8	9.0	10.1	11.2	14.3	17.1	19.5	21.0	24.0	26.0	27.3		
CN613	35.0	149	1.6	3.1	4.5	6.0	7.4	8.7	10.0	11.2	12.5	15.8	18.8	21.3	22.8	25.8	27.7	28.5		
CN614	39.5	166	1.7	3.4	5.0	6.6	8.2	9.6	11.0	12.4	13.7	17.4	20.6	23.3	24.8	27.8	29.5			
CN615	45.5	181	1.9	3.8	5.6	7.3	9.0	10.6	12.1	13.6	15.0	18.9	22.3	25.1	26.7	29.6	31.0			
CN616	47.5	201	2.1	4.1	6.1	8.0	9.8	11.5	13.2	14.8	16.3	20.5	24.0	26.8	28.4	31.1	32.0			
CN617	47.5	219	2.3	4.5	6.6	8.6	10.6	12.5	14.3	16.0	17.6	21.9	25.6	28.4	29.9	32.2				
CN618	55.0	236	2.5	4.9	7.2	9.4	11.5	13.5	15.3	17.2	18.9	23.6	27.4	30.3	31.8	33.9				
CN619	55.0	255	2.7	5.2	7.7	10.0	12.3	14.4	16.4	18.3	20.2	24.9	28.7	31.5	32.8	34.1				

Selection

1. Operating Conditions Required for Selection

- (1) Daily operating hours
- (2) Load characteristics and type of motor
- (3) Transmission power (kW) and rotation speed (r/min) or torque (N·m)
- (4) Outer diameters of both shafts

2. Method of Selection

- (1) Determine the service factor on the service factor table on the right based on operating conditions.
- (2) Obtain the design kW (torque) by multiplying the kW to be transmitted by the service factor.

- (3) With the required speed, choose the coupling which satisfies the kW from the Kilowatt Ratings Table.
- (4) When the required shaft diameter exceeds the maximum bore diameter of the coupling chosen, use a coupling one size larger.
- (5) In the low speed range, the bearing pressure may be too great when using a standard key. In this case, consider whether or not it will be necessary to use a special key or spline bore by calculating key bearing pressure.
- (6) When choosing a coupling for direct connection to a motor, refer to the Direct Motor Connection Selection Table below.

Table of Service Factors (SF)

Load Characteristics	Source of Power		
	Motor Turbine	Steam engine Gasoline engine (4 cylinders)	Diesel engine Gas engine
Low fluctuation, low impact, low starting torque, and no reverse rotation	1.0	1.5	2.0
Middle fluctuation, middle impact, and no reverse rotation (standard load)	1.5	2.0	2.5
High fluctuation, high impact, reverse rotation, and loaded starting	2.0	2.5	3.0

- Notel. An increase according to the operating hour of the chain coupling (provided that the rotation speed is 50 r/min. or more).
 8 to 16 hours/day: 0.5
 16 hours or more/day: 1.0
2. The above table shows rough service factor standards. Decide on the service factor according to the operating conditions.

Recommended Coupling Models for Direct Motor Connection

Motor output kW			Motor shaft dia. (mm)	Model no.
2P	4P	6P		
0.2	0.2	-	11	CN310
0.4	0.4	-	14	CN311
0.75	0.75	0.4	19	CN315
^{1.5} / _{2.2}	1.5	0.75	24	CN317
-	2.2	1.5	28	CN415
3.7	3.7	2.2	28	CN415
^{5.5} / _{7.5}	5.5	3.7	38	CN419
-	7.5	5.5	38	※CN614
¹¹ / ₁₅	11	7.5	42	※CN615
-	15	11	42	※CN616

- Notes: 1. Couplings marked ※ are not applicable to 2P motors.
 2. This table applies to regular loads (service factors of 1 to 1.5)

Safety Instructions

WARNING	Death or serious injury may result from misusing the product without following the directions given under this sign.
CAUTION	Minor or moderate injury, as well as damage to the product may result from misusing the product without following the directions given under this sign.

Note : Failure take heed of information labeled “CAUTION” may also lead to serious accidents depending on the situation.



WARNING

(General)

- Install a safety cover and prevent access to any rotating parts: otherwise injury may occur. Set a safety mechanism to stop the rotating parts when the cover is lifted.
- Transporting, installing, operating, maintaining or inspecting must be carried out by skilled and professional engineers to avoid mis-handling and hazardous situations.
- When coupling is used with vehicles that carry human, use a device to protect the vehicle: otherwise, accidents and damage may occur.
- When the coupling is used for an elevator, install a safety device on the elevator in order to prevent it from falling, which can cause damage and accidents resulting in death or injury.

(Unpacking upon delivery)

- If delivered in a wooden case, unpack with care. Sharp nails may cause injury.

(Additional machining)

- Never modify the coupling; the quality or function of the product may decrease and break or damage the machine or injure the operator.

(Transportation)

- Never step under the product when it is being elevated for transportation: otherwise, either the product or load may fall, causing accidents resulting in death or injury.

(Installation)

- Wear appropriate clothing and safety gear (safety goggles, gloves, shoes, etc.).
- Make sure the power is switched off, and the machine is completely stopped before installing. Take caution so that the power does not reconnect accidentally.
- Make sure to tighten and apply sufficient amount of anti-loosening agent to the hexagonal socket head cap screws.

(Operation)

- Avoid contact with any rotating parts (coupling, shaft, etc.) during operations. Rotating parts can catch approaching objects and cause serious injuries.

(Maintenance and inspection)

- Avoid contact with any rotating parts (coupling, shaft, etc.) during maintenance and inspection. Rotating parts can catch approaching objects and cause serious injuries.
- Make sure the power is switched off, and the machine is completely stopped before carrying out maintenance and inspection. Take caution so that the power does not reconnect accidentally. Make sure the driving and driven equipment are also completely stopped.



CAUTION

(General)

- Do not use coupling beyond its capacity as specified in the catalog. Exceeding its capacity can break the machine and cause injuries.
- Do not use damaged couplings. They can break your equipment and cause injuries.

(Transportation)

- Pay extra attention so that the equipment will not fall or rollover during transportations.

(Installation)

- Do not touch the edge and inner diameter of any part with bare hands to avoid possible injury.
- Make sure to align the drive and driven shafts as instructed in the manual when installing the coupling.

(Operation)

- Do not touch the coupling during operations to avoid injuries.
- Immediately stop the machine upon any sign of abnormal operation.

(Maintenance and inspection)

- Wear appropriate clothing and safety gear (safety goggles, gloves, shoes, etc.).
- Clean the surrounding area and maintain a clutter-free space to avoid secondary accidents.
- Comply with Ordinance on Labor Safety and Hygiene 2-1-1 general standards.
- Conduct periodic inspections to make sure that the drive and driven shafts are aligned as described in the manual, and that the rubber and plastic parts are not worn or deformed.

(Environment)

- Coupling scraps should be disposed as general waste by skilled professionals.
- This coupling meets RoHS (Restriction of Certain Hazardous Substances) standards and contains no hazardous chemicals.

Warranty

Tsubaki Emerson Co.: hereinafter referred to as "Seller"

Customer: hereinafter referred to as "Buyer"

Goods sold or supplied by Seller to Buyer: hereinafter referred to as "Goods"

1. Warranty period without charge

18 months effective the date of shipment or 12 months effective the first use of Goods, including installation of Goods to Buyer's equipment or machines - whichever comes first.

2. Warranty coverage

Should any damage or problem with the Goods arise within the warranty period, given that the Goods were operated and maintained under instructions provided in the manual, Seller would repair and replace at no charge once the Goods are returned to Seller. The following are excluded from the warranty.

- 1) Any costs related to removing Goods from the Buyer's equipment or machines to repair or replace parts.
- 2) Costs to transport Buyer's equipment or machines to the Buyer's repair shop.
- 3) Costs to reimburse any profit loss due to any repair or damage and consequential losses caused by the Buyer.

3. Warranty with charge

Seller will charge any investigation and repair of Goods caused by:

- 1) Improper installation by failing to follow the instruction manual.
- 2) Insufficient maintenance or improper operation by the Buyer.
- 3) Incorrect installation of Goods to other equipment or machines.
- 4) Any modifications or alterations of Goods by the Buyer.

5) Any repair by engineers other than the Seller or those designated by the Seller.

6) Operation in an inappropriate environment not specified in the manual.

7) Force Majeure or forces beyond the Seller's control such as natural disasters and injustice done by a third party.

8) Secondary damage or problem incurred by the Buyer's equipment or machines.

9) Defected parts supplied, or specified by the Buyer.

10) Incorrect wiring or parameter setting by the Buyer.

11) The end of life cycle of the Goods under normal usage.

12) Loss or damage not liable to the Seller.

4. Dispatch Service

Service to dispatch a Seller's engineer to investigate, adjust or trial test Seller's Goods is at the Buyer's expense.

5. Disclaimer

1) In our constant efforts to improve, Tsubaki Emerson may change the contents of this document without notice.

2) Considerable effort has been made to ensure that the contents of this document are free from errors. However, Tsubaki Emerson makes no warranties with respect to the accuracy of information described herein. In the mean time, we would appreciate comments or reports on any inaccuracies or omissions found in this document to help us make timely amendments as necessary. Your cooperation is greatly appreciated.



TSUBAKI EMERSON CO.

Manufacturer:TSUBAKIMOTO SPROCKET CO.

1-1, Kotari-Kuresumi, Nagaokakyo,
Kyoto 617-0833, Japan

<http://www.tsubaki-emerson.co.jp/>

Phone : +81-75-957-3131

Facsimile : +81-75-957-3122

Global Associated Partners:

NORTH and SOUTH AMERICA

U.S. TSUBAKI, INC.

301 E. Marquardt Drive
Wheeling, IL 60090-6497
U.S.A.

Phone : +1-847-459-9500

Facsimile : +1-847-459-9515

TSUBAKI of CANADA LIMITED

1630 Drew Road
Mississauga, Ontario, L5S 1J6
Canada

Phone : +1-905-676-0400

Facsimile : +1-905-676-0904

TSUBAKI BRASIL

REPRESENTAÇÃO COMERCIAL LTDA.

R. Pamplona, 1018 - CJ. 73/74
Jd. Paulista - 01405-001

São Paulo - S.P. Brazil

Phone : +55-11-3253-5656

Facsimile : +55-11-3253-3384

EUROPE

TSUBAKIMOTO EUROPE B.V.

Aventurijn 1200, 3316 LB Dordrecht
The Netherlands

Phone : +31-78-6204000

Facsimile : +31-78-6204001

TSUBAKIMOTO U.K. LTD.

Osier Drive, Sherwood Park
Annesley, Nottingham
NG15 0DX U.K.

Phone : +44-1623-688-700

Facsimile : +44-1623-688-789

ASIA and OSEANIA

TSUBAKIMOTO SINGAPORE PTE. LTD.

25 Gul Lane
Jurong

Singapore 629419

Phone : +65-6861-0422/3/4

Facsimile : +65-6861-7035

TSUBAKI INDIA POWER TRANSMISSION PVT. LTD.

Chandrika Chambers, No.4, 3rd Floor,
Antony Street, Royapettah,
Chennai - 600014 India

Phone : +91 44 4231 5251/28130252,

Facsimile : +91 44 4231 5253

TSUBAKIMOTO (THAILAND) CO., LTD.

999/9 The Offices at Centralworld
10th Floor, No.1001, Rama 1 Road
Pathumwan, Bangkok 10330 Thailand

Phone : +66-2-264-5354/5/6

Facsimile : +66-2-251-3912

TSUBAKI AUSTRALIA PTY. LTD.

Unit E, 95-101 Silverwater Road
Silverwater, N.S.W. 2128
Australia

Phone : +61-2-9704-2500

Facsimile : +61-2-9704-2550

TAIWAN TSUBAKIMOTO CO.

No.33, Lane 17, Zihciang North Road
Gueishan Township, Taoyuan County
Taiwan

Phone : +886-33-293827/8/9

Facsimile : +886-33-293065

KOREA CONVEYOR IND.CO,LTD

68B 7L,Namdong industrial Estate,
627-3,Gojan-dong,Namdong-gu,
Incheon Republic of Korea

Phone : +82-32-811-8723

Facsimile : +82-32-814-5811

TSUBAKI EMERSON MACHINERY (SHANGHAI) CO., LTD.

The 4th Building, No.1588 Gao Tai Rd.
Jiading Industry Zone, Shanghai, China 201821

Phone : 021-6916-9305/021-6916-9306

Facsimile : 021-6916-9308

Distributed by: